

Installation instructions

LORO flat roof drains

with connecting sleeve, O series

in accordance with EN 1253, DN 70, DN 100 and DN 125

System overview

	one-piece		two-piece	
	DN 70	DN 70	DN 70	DN 70
Vers. a	15275.070X	15475.070X	15285.070X	15485.070X
Vers. b	15375.070X	15575.070X	15385.070X	15585.070X

	one-piece				two-piece			
	DN 100	DN 125	DN 100	-	DN 100	DN 125	DN 100	-
Vers. a	17110.100A	17110.125A	17131.100A	-	17120.100A	17120.125A	17132.100A	-
Vers. b	17141.100A	17141.125A	17145.100A	-	17142.100A	17142.125A	17146.100A	-
Vers. c	17143.100A	17143.125A	17147.100A	-	17144.100A	17144.125A	17148.100A	-

Construction diagram DN 70

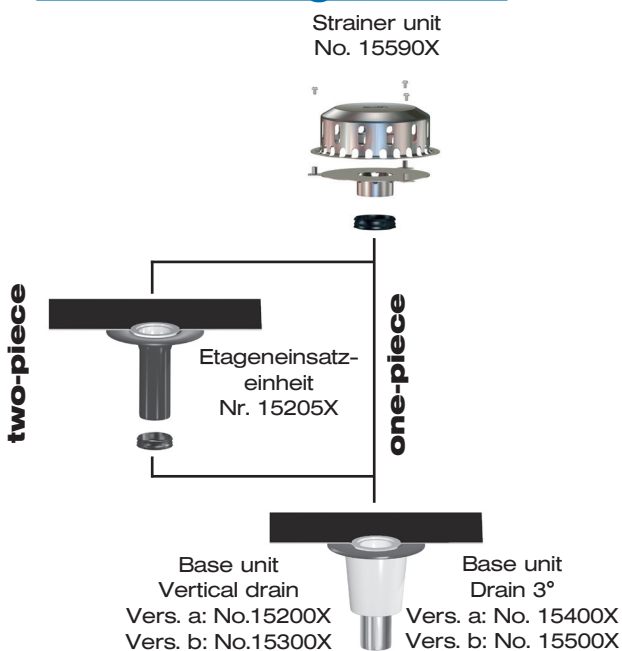

Construction diagram DN 100 and DN 125

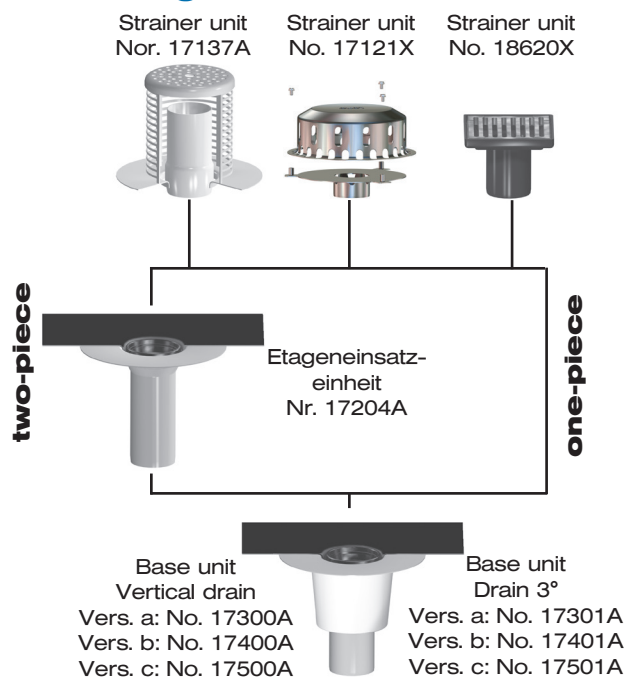

Vers. a = without thermal insulation, vers. b = with thermal insulation, vers. c = with thermal insulation and heating

1.) Connection of LORO connecting sleeve with roof sealing sheets

The connecting sleeve of LORO flat roof drainage systems, O series, consists of bitumen/EPDM compound, PVC or ECB. **Please ask at the LOROWERK factory if you require connecting sleeves for roof sealing sheets other than those described below.**

a) Combination connecting sleeve made of polymer-bitumen/EPDM compound for joining to two-layer bituminous sealing sheets.

The combination connecting sleeve Y 500 x 3.0 mm is a sealing sheet based on EPDM (synthetic rubber).

It incorporates a polymer-modified bituminous top layer and an adhesive bottom layer.

It also contains glass fibre fabric. Manufacturer: Phoenix, type Resitrix.

The combination connecting sleeve is joined to the sealing sheet using hot bitumen (in the hot bitumen gluing or the hot bitumen welding process).

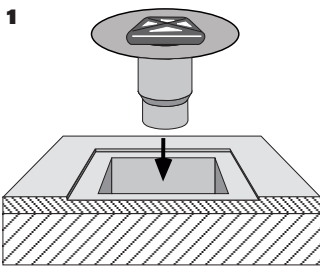

One-piece version:

- 1 Insert the drain pot in the slab cut-out and fasten it. The flange should be mounted into the substrate as flush as possible with the surface. See pages 5 and 6 for the cut-out dimensions.

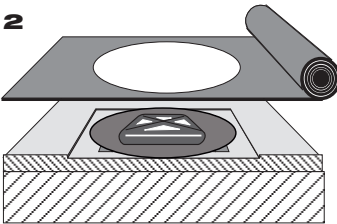

- 2 Make holes in the **lower** roof sealing sheet and roll it out over the drain.

Hole dimensions for drains:

DN 70 = 230 mm, DN 100 = 330 mm, DN 125 = 330 mm

Note: The flange must remain clear!

Thoroughly clean all the contact surfaces (they must be free from grease and dust), and if there is a protective foil on the LORO connecting sleeve, remove it.

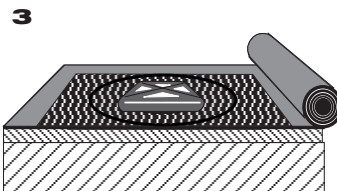

- 3 Apply bituminous adhesive (hot bitumen) to the roof sealing sheet in the area of the contact surface, or liquefy the bituminous material on the lower sealing sheet by heating it. Make sure when using hot-bitumen gluing, that extreme heating (e.g. use a torch to dry the substrate) is not applied to the lower side of the connecting sleeve.

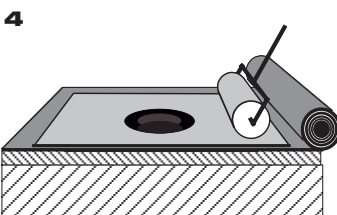

- 4 Spread the connecting sleeve in the liquid hot bitumen (in the hot bitumen gluing process) or in the liquid bituminous material of the bitumen welding sheet (welding process), and then evenly push or roll the connecting sleeve down.

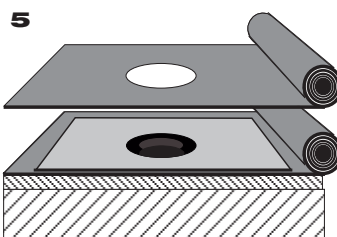

- 5 Unroll the **top** sealing sheet over the drain. Cut a circular hole in the sealing sheet in the region of the drain – hole diameter approx. 150 mm. **Note: The connecting sleeve must not be damaged!** Roll back the sealing sheet.

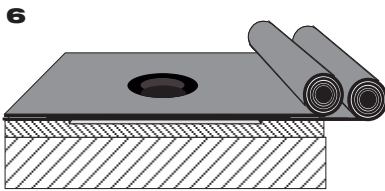

- 6** Apply hot bitumen to the top side of the connecting sleeve (hot bitumen gluing process), or liquefy the bituminous material of the connecting sleeve by heating it (welding process). Unroll the roof sealing sheet again over the drain in the hot liquid bitumen, and then press or roll it down evenly.

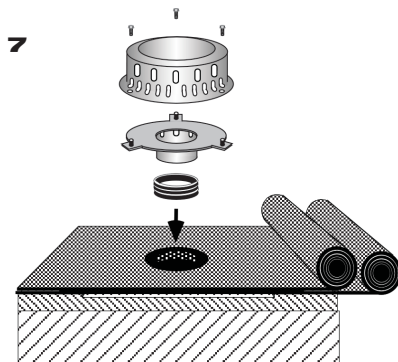

- 7** Place the strainer and the strainer cover into the clamping ring of the drain pot.

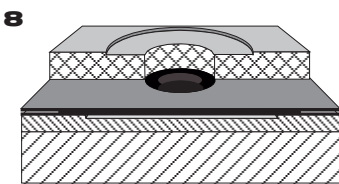

Two-piece version:

- 8** Cut out the thermal insulation according to the dimensions of the extension cartridge.

Important: Cut out a space for the flange as well, as it should be flush-mounted into the substrate as far as possible.

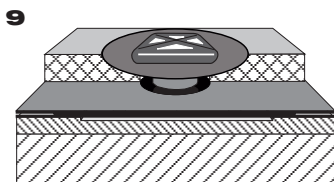

- 9** Place the extension cartridge into the drain pot in a backflow-safe manner (for DN 70 with sealing element in the clamping ring, for DN 100 - DN 125 place directly into the clamping ring). For installation heights/thermal insulation thickness see **2.)** Page 4.

- 10** Connection of the connecting sleeve to the sealing sheet and installation of the strainer and the strainer receptacle are as described under 1) - 7).

Clamping of the combination connecting sleeve by the customer

Normally the combination connecting sleeve is clamped in place at the factory. If on-site clamping is necessary, proceed as follows:

- 1.) Only use a combination connecting sleeve that has been pre-shaped at the factory.
- 2.) Place the combination connecting sleeve centrally over the fitted drain. The bituminous layer faces upwards.
- 3.) Heat the bituminous layer of the combination connecting sleeve in the area of the holes (clamping area) with an open flame or hot-air device. The surface must be shiny (but there must be no flame).
- 4.) Place the clamping ring centrally over the holes, and push it evenly, firmly and deeply into the pre-shaped, heated holes of the combination connecting sleeve. It may be necessary to push the clamping ring with a vertical wooden board in order to make sure that the pressing force is even.
- 5.) Allow the combination connecting sleeve to cool down somewhat before further processing.
- 6.) Connect the combination connecting sleeve to the sealing sheet (see above for the procedure).

b) PVC connecting sleeve for connecting to PVC sealing sheets made from plasticized polyvinyl chloride in accordance with DIN 16730 - e.g.: PVC-P-NB

The PVC connecting sleeve Y 500 x 1.5 mm is a sealing sheet in accordance with DIN 16730 based on polyvinyl chloride (PVC-P-NB), manufacturer Braas, type Rhenofol C.

The PVC connecting sleeve is connected to the existing PVC sealing sheet by means of solvent welding or hot gas welding.

Hot-gas welding is preferable at low ambient temperatures - associated with high air humidity.

Observe the manufacturer's instructions for jointing to sealing sheets.

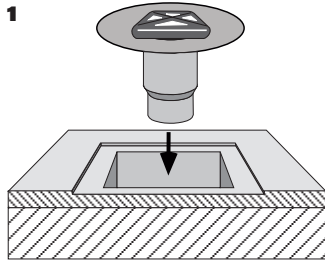

One-piece version:

- 1 Insert the drain pot in the slab cut-out and fasten it. The flange should be mounted into the substrate as flush as possible with the surface. See pages 5 and 6 for the cut-out dimensions.

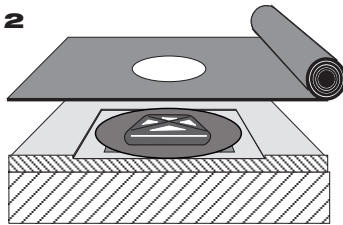

- 2 Unroll the sealing sheet over the drain. Cut a circular hole in the sealing sheet in the region of the drain – hole diameter approx. 150 mm.

Note: The connecting sleeve must not be damaged.

Thoroughly clean all the contact surfaces (they must be free from grease, free from dust and dry).

First remove the protective foil from the LORO connecting sleeve. If the temperature is less than +5° C, pre-heat the area of the seam using the hot gas hand-welding unit.

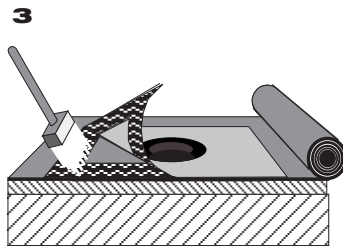

- 3 Apply solvent welding agent every 50 mm to both sides of the seam region, and press down by hand. Then load the seams (e.g. with a sandbag). When using hot gas welding, close the seam with the hot gas hand-welding unit and pressure roller or with a welding machine.

- 4 Check the seams and rework them if necessary.

Two-piece version: see 8 - 10, page 3.

2.) Extension cartridge

Extension cartridge DN 100 - DN 125: No. 17117A or DN 70: No. 15578X, for the two-piece version (used in roof structure with thermal insulation) seal into the clamping ring of the drain pot (for DN 70 using sealing element no. 911X) in a backflow-safe manner.

Adjustment ranges:

	Roof drains steel, DN 70		Roof drains aluminium, DN 100 - 125	
	Adjustment ranges	Instructions for laying	Adjustment ranges	Instructions for laying
for vertical drain pot	40 - 80 mm	cut to length	40 - 70 mm	cut to length
	80 - 120 mm	continuously adjustable	70 - 180 mm	continuously adjustable
	120 - 230 mm	with ext. pipe, no. 15587X, can be trimmed to length	180 - 290 mm	with ext. pipe, no. 15587X, can be trimmed to length
for side drain pot	40 - 120 mm	cut to length	40 - 180 mm	cut to length
	120 - 230 mm	with ext. pipe, no. 15587X, can be trimmed to length	180 - 290 mm	with ext. pipe, no. 15587X, can be trimmed to length

3.) Wet roof drain (only for aluminium roof drains, DN 100 - DN 125)

The widened end of the standpipe is inserted with the help of lubricant into the clamping ring of the drain funnel.

The maximum backflow level of 175 mm can first be reduced by trimming back the top end to the desired length.

4.) Protective cover

The drain pots of the LORO roof drains are supplied with a protective cover. This prevents dirt from getting into the drain pot or the down pipe during assembly. With two-piece roof drains, the protective cover should be moved to the extension cartridge after the drain has been assembled. The protective cover is removed when assembly has proceeded far enough.

5.) Strainer cover (only for aluminium roof drains, DN 100 - DN 125)

Strainer covers, no 17112A, have a hole that matches commercially available heating elements.

6.) Heating (only for aluminium roof drains, DN 100 - DN 125)

Electrical version:

Rated voltage (V): 230 V, max. permitted ambient temperature: +80°C

Rated power in watts: approx. 20 watt

Circuit breakers with C-characteristic and residual-current circuit breakers (RCCB) 30 mA are to be fitted.

Can be connected without pre-transformer.

Connecting cable type H07-RN-F 3G1.5, approx. 1.0 m long, max. permitted storage temperature +80°C

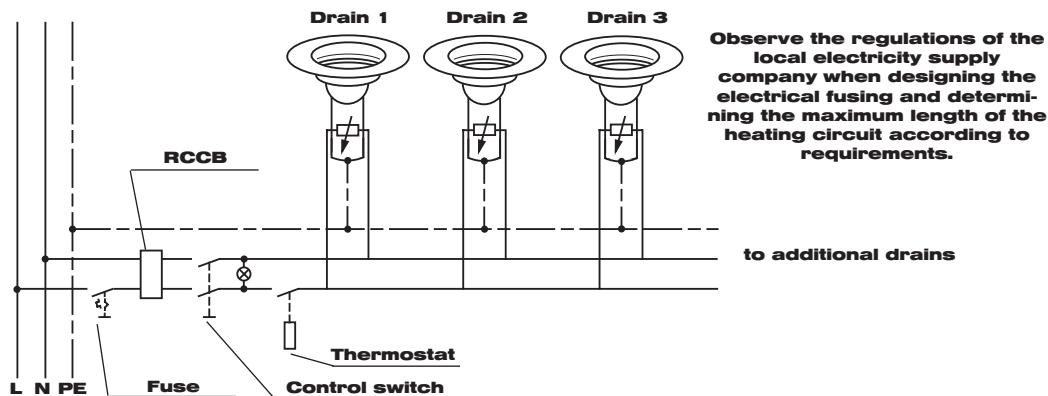

Heated roof drains can be connected individually or in parallel.

An external thermostat (plus humidity controllers in large installations) together with an on-off regulator provide automatic central control. The components required for this are commercially available, for instance from suppliers of heating control systems. Heated roof drains must not be shortened or modified on site.

Heated roof drains must only be connected by qualified electricians. The applicable VDE

(German Electricians' Association) regulations and power supply company regulations must be observed.

7.) Cut-out dimensions for DN 70 roof drains

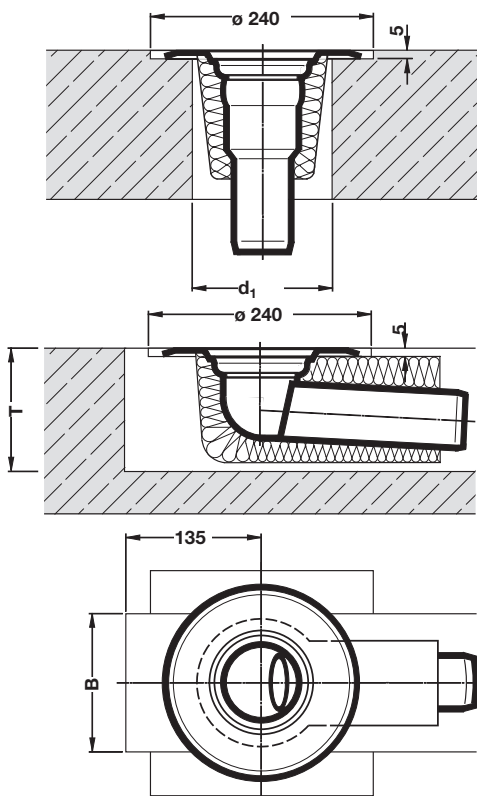

Roof drain DN 70 Vertical drain

DN	d ₁
70	122/158*

* Core hole for drain pot with thermal insulation

Roof drain DN 70 Side drain

DN	Cut-out depth T		Cut-out width B	
	a	b	a	b
70	130	140	130	160

a = without thermal insulation

b = with thermal insulation

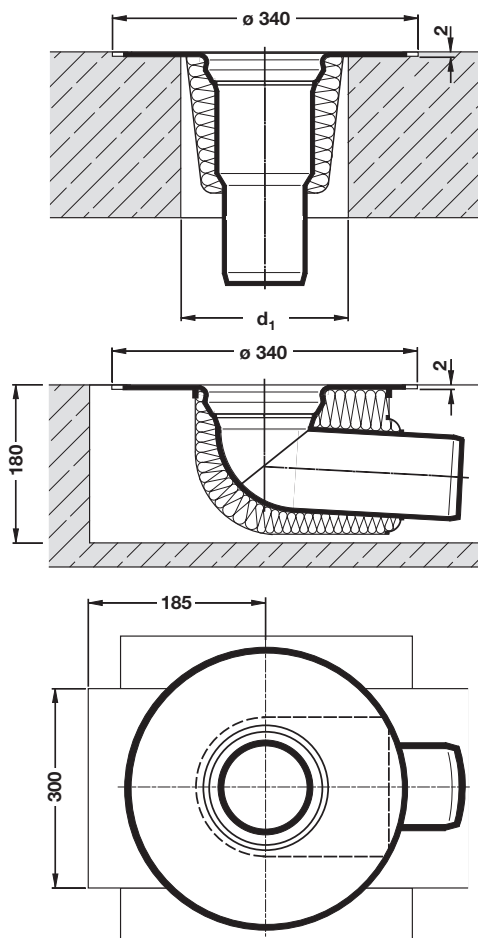
8.) Cut-out dimensions for roof drains DN 100 - DN 125

**Roof drain DN 100 and DN125
Vertical drain**

DN	d ₁
100	160/200*
125	190/230*

* Core hole for drain pot with thermal insulation

**Roof drain DN 100
Side drain**

Prepare and attach a lower shuttering panel for filling. Lift the drain a little and fill. Return the drain to its position.

9.) Concreting in

If the roof drains are to be concreted in, they must first be fastened in such a way that their position will not change.

10.) Trace heating

After checking the roof drains and pipes in areas endangered by frost, we recommend that customers install trace heating if necessary.

Connecting sleeves for DN 70 flat roof drainage systems available in:

Nr. 15593X	Resitrix	Bitumen/EPDM compound - Standard	Nr. 15009X	Hertalan	EPDM
Nr. 15596X	Rhenofol	PVC	Nr. 15011X	Trocal S	PVC
Nr. 15003X	Themoplan	FPO	Nr. 15012X	Alkorplan	PVC
Nr. 15005X	Evalon	EVA	Nr. 15015X	Thermofol	PVC
Nr. 15006X	Wolfen IB	PVC-BV	Nr. 15016X	Flagon	FPO
Nr. 15008X	Novotan	EPDM	Nr. 15007X	Sarnafil	FPO
Nr. 15002X	Evalon	EVA	Nr. 15010X	Evalastic	EPDM

Connecting sleeves for DN 100 and DN 125 flat roof drainage systems available in:

Nr. 17000A	Resitrix	Bitumen/EPDM compound - Standard	Nr. 17009A	Hertalan	EPDM
Nr. 17596A	Rhenofol	PVC	Nr. 17011A	Trocal S	PVC
Nr. 17003A	Themoplan	FPO	Nr. 17012A	Alkorplan	PVC
Nr. 17005A	Evalon	EVA	Nr. 17013A	Rhepanol	PIB
Nr. 17006A	Wolfen IB	PVC-BV	Nr. 17015A	Thermofol	PVC
Nr. 17008A	Novotan	EPDM	Nr. 17016A	Flagon	FPO
Nr. 17007A	Sarnafil	FPO	Nr. 17002A	Evalon	EVA
Nr. 17010A	Evalastic	EPDM			

Unless otherwise specified by the ordering party, a connecting sleeve of bitumen/EPDM compound will be supplied. If sealing sheet already present on-site (without woven or non-woven fabric inlay) is to be clamped, please discuss the application options beforehand with the LOROWERK factory.

LOROWERK K.H.Vahlbrauk GmbH & Co.KG

Kriegerweg 1, 37581 Bad Gandersheim, Tel.: +49 53 82.710, Fax: +49 53 82.712 03

Web: www.loro.de, e-mail: infocenter@lorowerk.de